

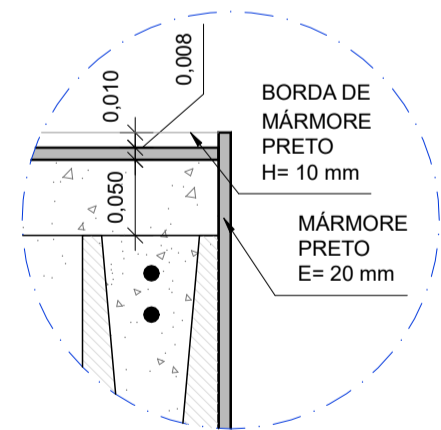

Prefeitura Municipal de Itapevi
Secretaria de Infraestrutura e serviços urbanos

Rodovia Eng. Renê Benedito Silva, 2235 – Vila Gioia | Itapevi | São Paulo | CEP: 06660-000 - Tel.: (11) 4144-9290 e-mail: sisu.obras@itapevi.sp.gov.br

Diretoria de Obras: Rua Agostinho Ferreira Campos, 675 –Vila Nova Itapevi | Itapevi | São Paulo | CEP: 06693-120 - Tel.: (11) 4143-7600 | sisu.diretoria@itapevi.sp.gov.br

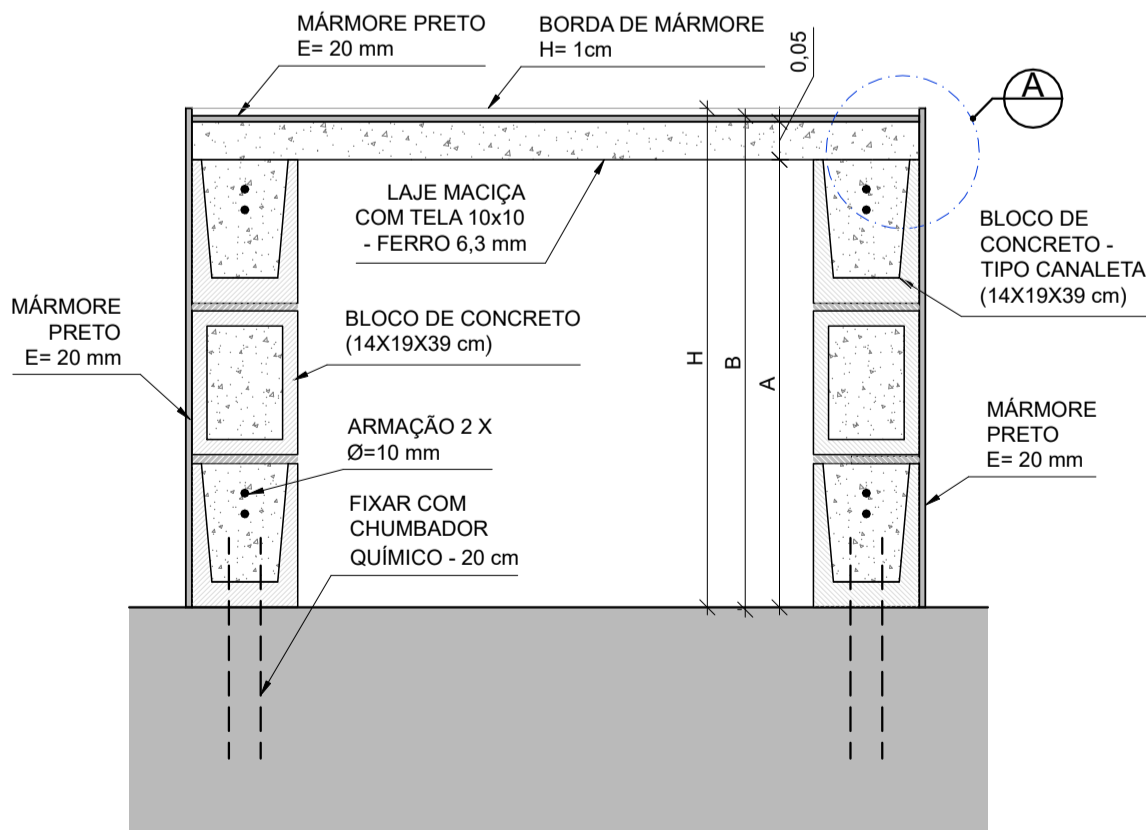
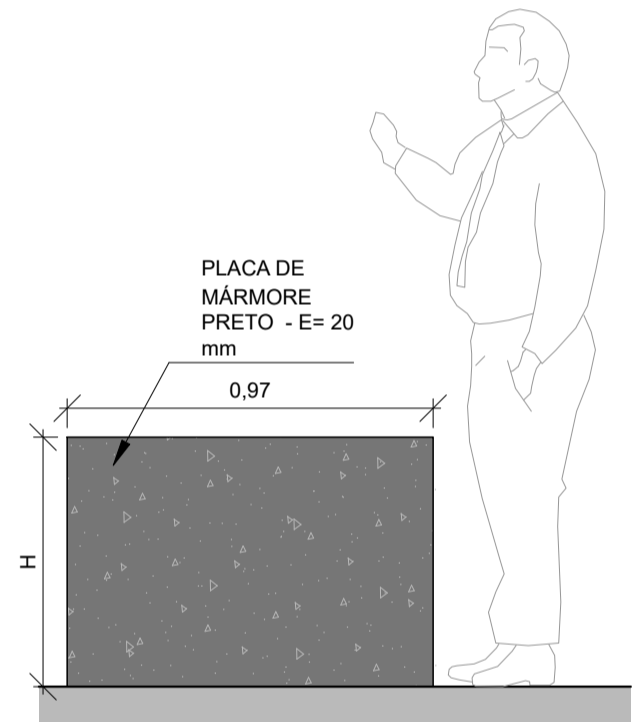
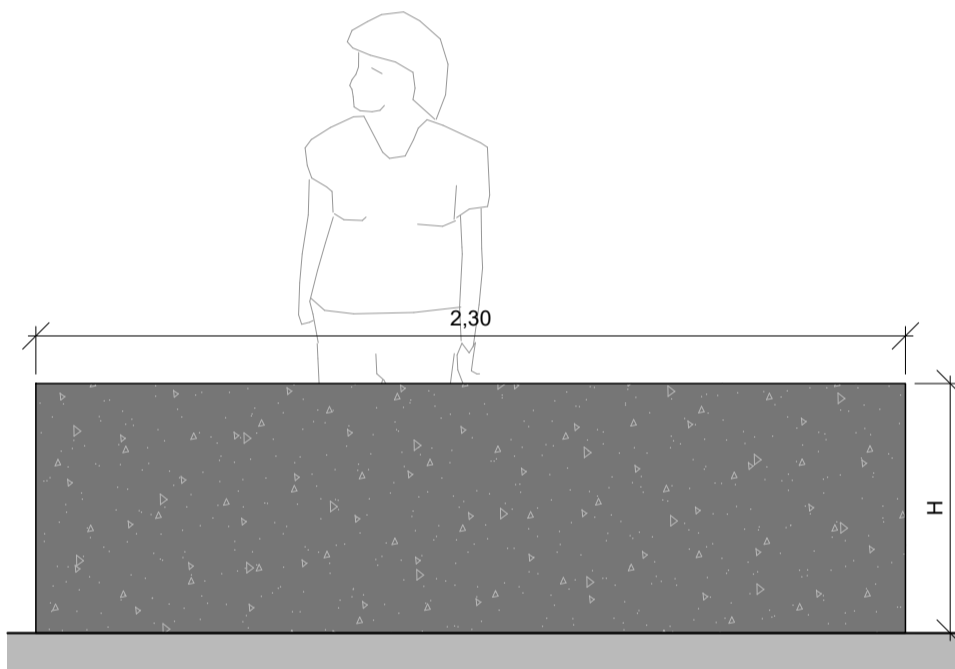
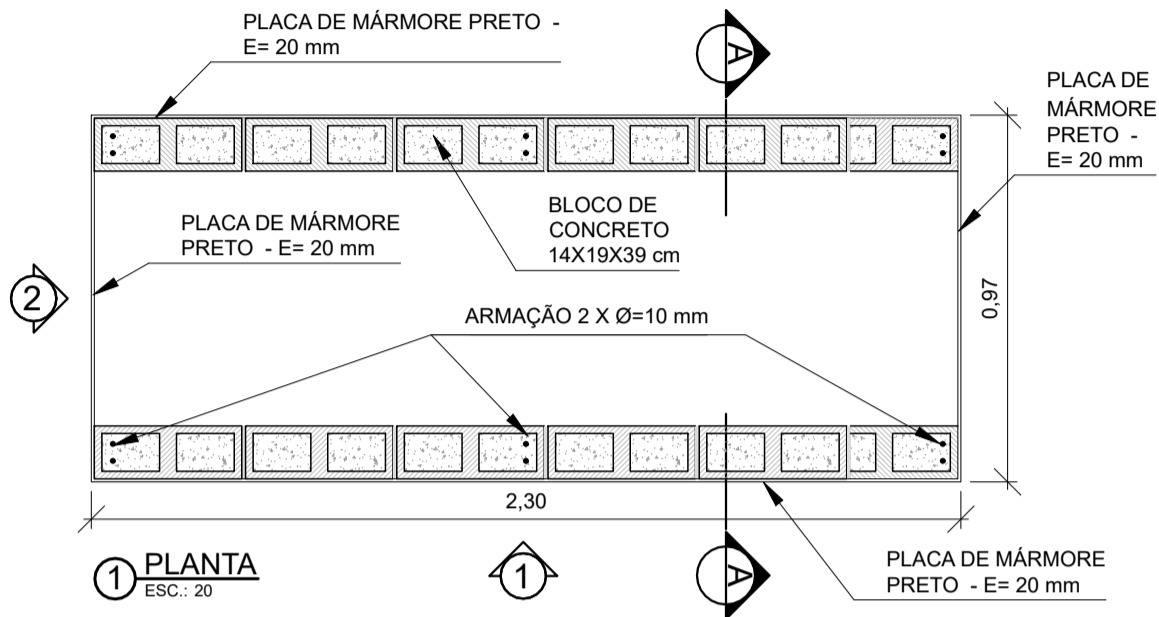

LEGENDA		
	MODELO 1	MODELO 2
A	59 cm	45 cm
B	65 cm	50 cm
H	66 cm	51 cm